



Downstream pressure reducing stabilizing valve with solenoid control Mod. XLC 315/415

The CSA model XLC 315/415 is a globe pattern hydraulically operated automatic control valve that reduces and stabilizes the downstream pressure to a constant value, regardless of variation in demands and upstream pressure conditions. Thanks to a solenoid control the valve will also open or close in response to a signal. Normally equipped with visual position indicator and entirely made in ductile cast iron with FBT epoxy coating and stainless steel, the valve is designed to reduce head loss, throttling noise and cavitation damage.

Applications

- On the by-pass line of storage tank to ensure the required water supply and pressure control during maintenance.
- As a protection against rise in pressure of industrial equipments and civil installation with on-off control from remote for alarms and emergencies.
- Energy saving with controlled pumping and water supply hours.

Accessories

- Linear position transmitter with 4-20 mA output Mod. CSA CSPL.
- On-off position transmitter Mod. CSA CSPO.
- Pressure measurement kit.
- Self-flushing and high capacity filter.

Note to the engineer

- Inlet pressure, outlet pressure, flow rate and application are required for the proper sizing and cavitation analysis.
- CSA anti-cavitation low flow stability plugs are recommended to provide an accurate regulation in case of low flow conditions.
- A minimum length of 3 DN downstream of the valve is recommended for the best accuracy.

Additional features

- XLC 315/415-FR downstream pressure reduction valve with solenoid control and back-flow prevention system.
- XLC 315/415-H downstream pressure reduction and solenoid control with high sensitivity pilot.
- XLC 315/415-G downstream pressure reduction valve with solenoid control and over pressure guard system.

Working conditions

- Fluid: treated water.
- Minimum operating pressure: 0,7 bar.
- Maximum operating pressure: 16 bar. Higher on request.
- Maximum temperature: 70°C.

Downstream pressure pilot adjustment range

- Blue spring: 0,7 to 7 bar.
- Red spring: 1,5 to 15 bar
- Values lower than 0,7 available with high sensitivity pilots.

Solenoid electrical data

- Voltages: 24 V DC, 24 V/50 Hz, 230 V/50 Hz. Other voltages on request.
- Power consumption: inrush AC (VA) 24, hold AC (VA) 17 (8 W), DC hot/cold coil 8/9 W.

Operating principle

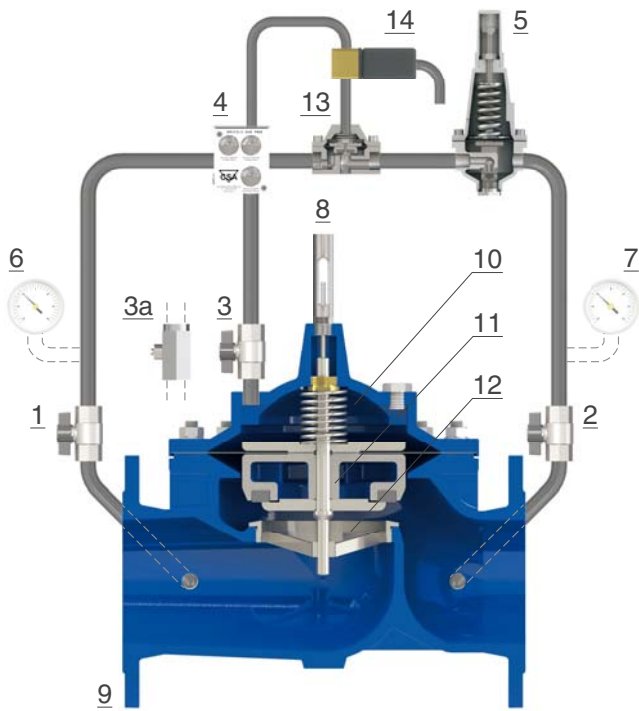

The CSA Model. XLC 315/415 is an automatic control valve operated by a two ways pilot (5), for downstream pressure reduction with pre-set adjustable value, and a solenoid valve (14) acting on a flow accelerator (13) to allow for normally open or normally closed function. Should the impulse to the solenoid (14) be set to have the flow accelerator (13) open if the downstream pressure rises above the pilot's set point (5) the latter will throttle, and limit the flow to divert line pressure to the main chamber (10), this to move the obturator down and generate the head loss required for the valve (9) to stabilize and maintain the desired downstream pressure. Should the downstream pressure fall below the pilot set point the obturator (11) will raise increasing the passage through the seat (12), reducing the head loss followed by the rise in pressure. The flow in and out of the main chamber (10) is controlled by the CSA exclusive unit regulation device with filter called GR.I.F.O. (4) and provided with three flow stabilizers, needed for the valve's response time and accuracy.

Installation layout

Sectioning devices (1, 2) and by-pass are very important for maintenance operations, as well as the filter (3) to prevent dirt from reaching the control valve. The valve is receiving impulses to the solenoid from a CSA controller (8) or a remote signal. The direct acting pressure reducer VRCD (4) is the best choice on the by-pass thanks to its reliability also after long periods of inactivity. Anti-surge air valves FOX 3F AS (6, 7) are recommended as well as a pressure relief valve VSM (5), to prevent rise in pressure on the line.

