

Utility Range

# Clamping and Installation Tools

## Product Range Overview

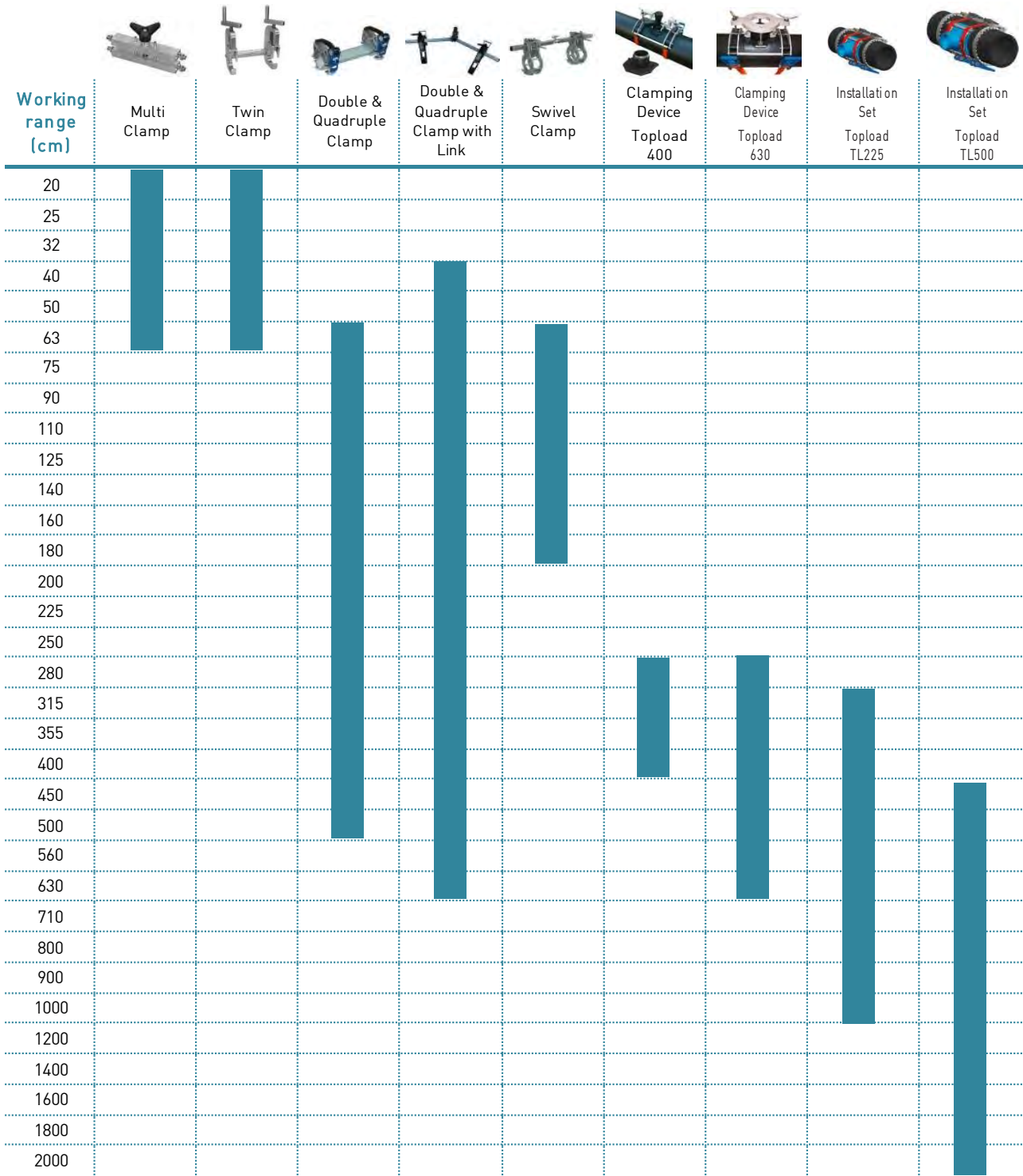

# Pipe clamps



## Twin clamp

- The easy-to-use Twin Clamp is suitable for coupler connections on straight or coiled pipe. The clamps prevent pullout and pipe movements during the fusion and cooling time.
- Scope of delivery: 1 complete tool.

d (mm)	Code	Weight (kg)
20	<b>799 301 536</b>	0.658
25	<b>799 301 537</b>	0.471
32	<b>799 301 538</b>	0.756
40	<b>799 301 539</b>	1.079
50	<b>799 301 540</b>	1.326
63	<b>799 301 541</b>	1.618



## Multi clamp

- This tool is quick and easy to use and is suitable for straight forward connections to straight lengths of pipe or saddle branch outlets with electrofusion couplers.
- Scope of delivery: 1 tool without accessories.

d-d (mm)	Code	Weight (kg)
20 - 63	<b>799 301 575</b>	0.800



## Inserts for multi clamp

- The inserts are easily and quickly exchanged. A set consists of 4 inserts, each insert with 2 different dimensions.

d-d (mm)	Code	Weight (kg)
25 - 20	<b>799 150 385</b>	0.500
32 - 20	<b>799 150 386</b>	0.500
32 - 25	<b>799 150 387</b>	0.500
40 - 32	<b>799 150 388</b>	0.500
50 - 40	<b>799 150 389</b>	0.500
63 - 32	<b>799 150 390</b>	0.500
63 - 40	<b>799 150 391</b>	0.500
63 - 50	<b>799 150 392</b>	0.500



## Double clamp

- The user-friendly Double Clamps are suitable for coupler connections. They are quickly and easily put into position and prevent pullout and pipe movements during the fusion time and cooling time.
- Scope of delivery: 1 tool consisting of 1 beam (compact), 2 V-clamps complete with ratchet and belt.



d-d (mm)	Code	Weight (kg)
63 - 125	<b>799 301 484</b>	3.506
110 - 225	<b>799 301 486</b>	7.918
225 - 500	<b>799 301 488</b>	14.735



### Quadruple clamp

- The professional Quadruple Clamps are suitable for coupler connections. They are quickly and easily put into position and ensure a stress-free fusion. They prevent pullout and pipe movements during the fusion and cooling times.
- Recommended for difficult site conditions with large installation-induced stresses.
- Scope of delivery: 1 tool consisting of 1 beam (long), 4 V-clamps complete with ratchet and belt.

d-d (mm)	Code	Weight (kg)
63 - 125	<b>799 301 459</b>	7.142
110 - 225	<b>799 301 461</b>	16.490
225 - 500	<b>799 301 463</b>	28.500



### Spare parts for clamps

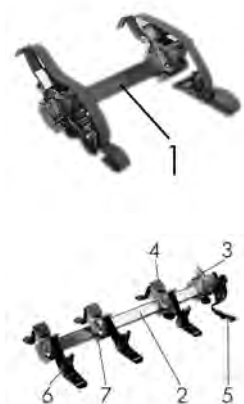

Pos	Dimension (mm)	Code	Weight (kg)
1	63-125, 45mm	<b>799 900 414</b>	1.700
	110-225, 60mm	<b>799 900 405</b>	3.500
	225-500, 80mm	<b>799 900 394</b>	6.000
2	63-125, 45mm	<b>799 900 413</b>	3.600
	110-225, 60mm	<b>799 900 404</b>	6.500
	225-500, 80mm	<b>799 900 387</b>	11.500
4	63-125	<b>799 900 421</b>	0.977
	110-225	<b>799 900 423</b>	2.000
	225-500	<b>799 900 425</b>	4.500
7	63-125	<b>799 150 313</b>	0.232
	110-225	<b>799 150 315</b>	0.496
	225-500	<b>799 150 319</b>	1.415
7		<b>799 150 314</b>	0.050



### Double clamp with universal link

- Recommended for the installation of fittings ELGEF Plus and ecoFIT d40 - 200 and d160 - 630mm
- Recommended for the installation of fittings COOL-FIT d32/D75 - d140/D200 and d160/D250 - d450/D630
- The clamping allows installation without tension and avoids movement during fusion and cooling time
- The centrally located adjustable universal link allows installation of electrofusion couplers, elbows and reducers
- Works above, below and alongside the joint
- Adaptor for use with Tee-pieces available (see accessories)

d (mm)	d1 (mm)	Code	Weight (kg)
40	200	<b>799 301 490</b>	4.200
160	630	<b>799 301 496</b>	14.100



### Quadruple clamp with universal link

- Recommended for the installation of fittings ELGEF Plus and ecoFIT d40 - 200 and d160 - 630mm
- Recommended for the installation of fittings COOL-FIT d32/D75 - d140/D200 and d160/D250 - d450/D630
- The clamping allows installation without tension and avoids movement during fusion and cooling time
- The centrally located adjustable universal link allows installation of electrofusion couplers, elbows and reducers
- Universal use; works above, below and alongside the joint
- Adaptor for use with Tee-pieces available (see accessories)

d (mm)	d1 (mm)	Code	Weight (kg)
40	200	<b>799 301 489</b>	8.300
160	630	<b>799 301 495</b>	23.300



### Tee adaptor

- Suitable for clamping tool (799301489 - 495)

d (mm)	d1 (mm)	Code	Weight (kg)
40	200	<b>799 301 491</b>	0.610
160	630	<b>799 301 497</b>	3.500



### V-block

- Suitable for clamping tool (799301489 - 495)

d (mm)	d1 (mm)	Code	Weight (kg)
40	200	<b>799 301 492</b>	1.000
160	630	<b>799 301 498</b>	3.200



### Bar extension

- Suitable for clamping tool (799301489 - 495)

d (mm)	d1 (mm)	Code	Weight (kg)
160	630	<b>799 301 499</b>	1.000



### Swivel clamp

- The Swivel Clamp centralises pipes with dimensions from d63 to 180 mm automatically. Suitable for coupler connections as well as reductions and bends. The 15° adjustment makes an exact positioning from 15° to 90° possible.

d-d (mm)	Code	Weight (kg)
63 - 180	<b>799 350 358</b>	13.000

# Topload clamps



## Clamping device topload 400

- This clamp and mounting tool is used for top-load Saddles on pipes.
- Proper use: ELGEF Plus electrofusion saddles dimension d280-400mm with outlet d63mm
- Scope of delivery: 1 base mounting clamp, 1 bracket, 2 clamping screws, 2 ratchet straps, 1 transport box

d-d (mm)	Code	Weight (kg)
280 - 400	<b>799 350 475</b>	20.000



## Clamping device topload 630

- This clamp and mounting tool is used for top-load Saddles on pipes.
- Proper use: ELGEF Plus electrofusion saddles dimension d280-400mm with outlet d63mm ELGEF Plus Branch fitting for dimension d280-630mm with outlet d90/110/125mm
- Scope of delivery: 1 base mounting clamp, 1 clamping attachment, 1 bracket, 2 clamping screws, 2 ratchet straps, 1 transport box

d-d (mm)	Code	Weight (kg)
280 - 630	<b>799 350 477</b>	28.400



## Clamping attachment topload 630

- Clamping attachment as single part for extension of Topload tool 400 (799 350 475)
- Suitable for Branch fittings dimension d 280 mm – 630 mm

d-d (mm)	Code	Weight (kg)
280 - 630	<b>799 350 476</b>	11.343

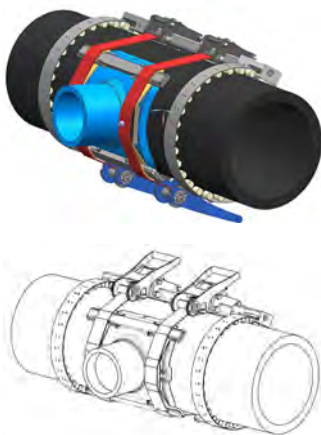

## Installation set Topload TL 225

- Suitable for branch saddle d315-1000mm with spigot outlet d160/d225
- Use of set is mandatory for the installation of branch saddles
- Set includes frame with tension belts, peeling tool, clamp and transport box
- Patent pending

Code	Weight (kg)
<b>799 300 807</b>	48.000



### Installation set Topload TL 500

- Suitable for ELGEF Plus branch saddle d450-2000mm with spigot outlet d315 and d500
- Use of set is mandatory for the installation of branch saddles
- Set includes frame with tension belts, peeling tool, clamp for outlet d315mm/500mm and transport box
- Patent pending

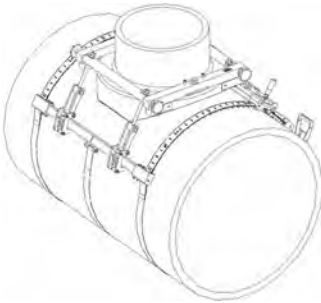

**Code Weight**  
(kg)

**799 300 809 124.000**



### Accessories / single parts for Installation set Topload



**Description Code Weight**  
(kg)

Transport box TL 225 (860x700x180)	<b>799 300 923</b>	18.500
Frame TL 225 incl. tension belt up to 1000mm	<b>799 300 820</b>	14.000
Peeling tool TL 225	<b>799 300 835</b>	5.600
Clamp TL 225	<b>799 300 920</b>	9.900
Peel cutter TL	<b>799 300 831</b>	0.066



### Multiple use assembly tool branch saddle d140mm

- Only to be used with Branch Saddle d140mm
- Delivered as complete Kit including screws and belt

**d Code Weight**  
(mm) (kg)

**140 193 281 027 0.724**